

# 2 W7 30

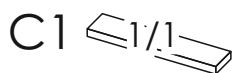

- ① -C1
- ② -C1
- ③ -C1

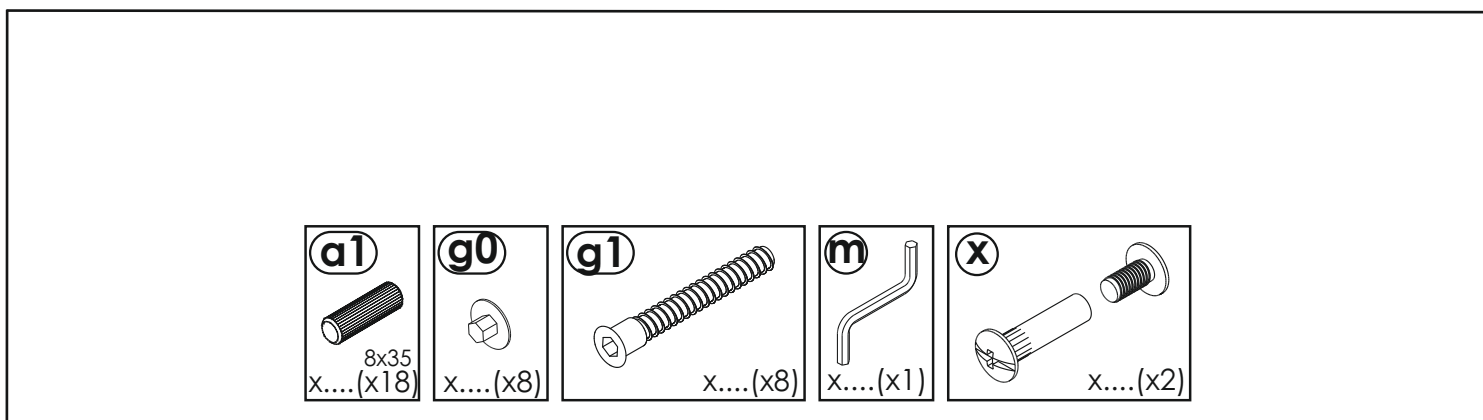
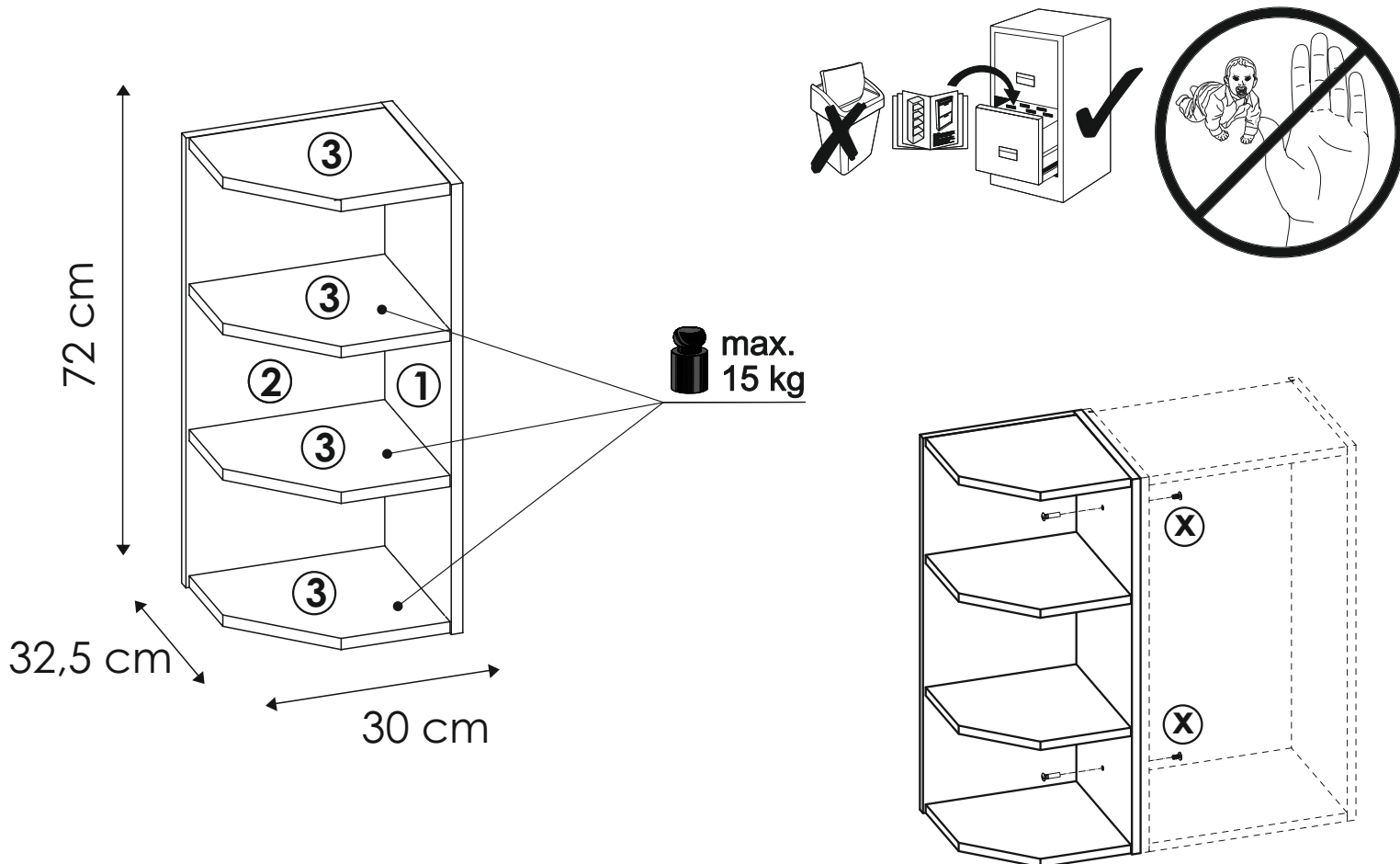